

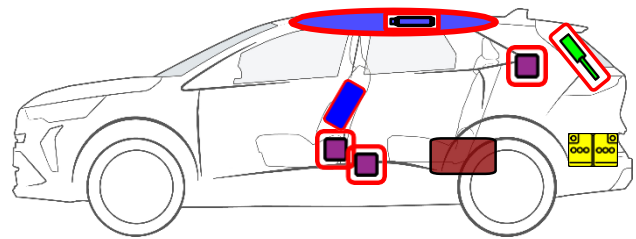

RENAULT

Captur 2 E-Tech Full Hybrid Phase1&2

(2021 -)

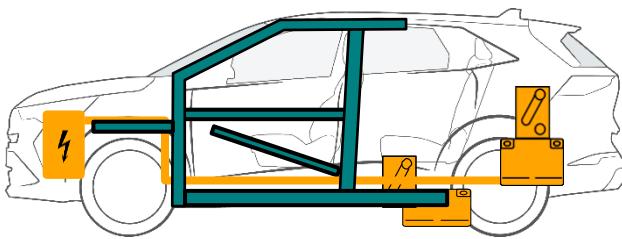
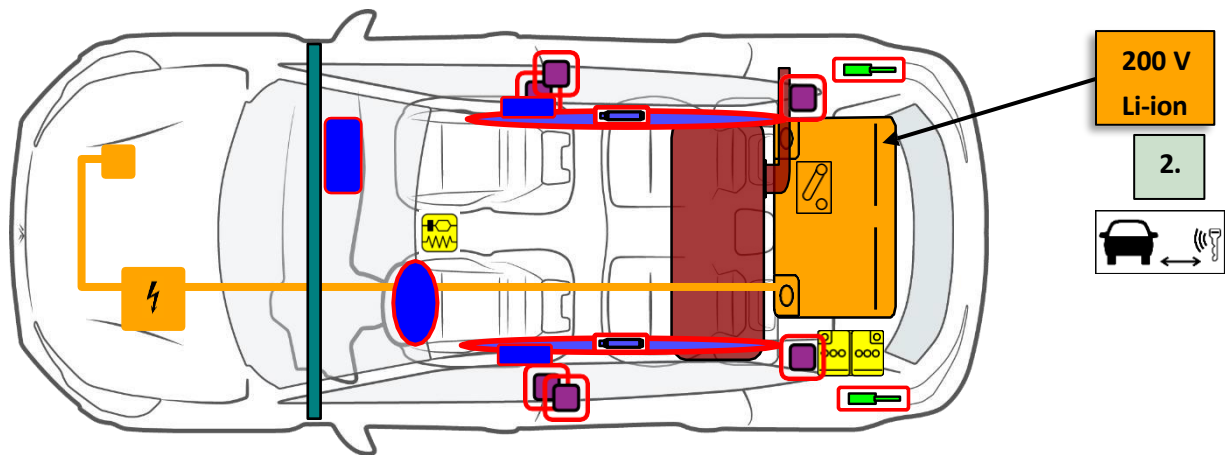

	Airbag		Stored gas inflator		Seat belt pretensioner		SRS control unit		
	Battery low voltage		Gas strut / Preloaded spring		High strength zone		Zone requiring special attention		Fuel tank content gasoline/ethanol
	Battery pack, high-voltage		High voltage power cable		High voltage device that disconnects high voltage		High voltage component		

In consultation with



MINISTÈRE DE L'INTÉRIEUR

Internal reference

RS-HJB HEV_ph1&2_2024

Date

01/08/2024

Version

1

Page

1 / 4

1. Identification / recognition

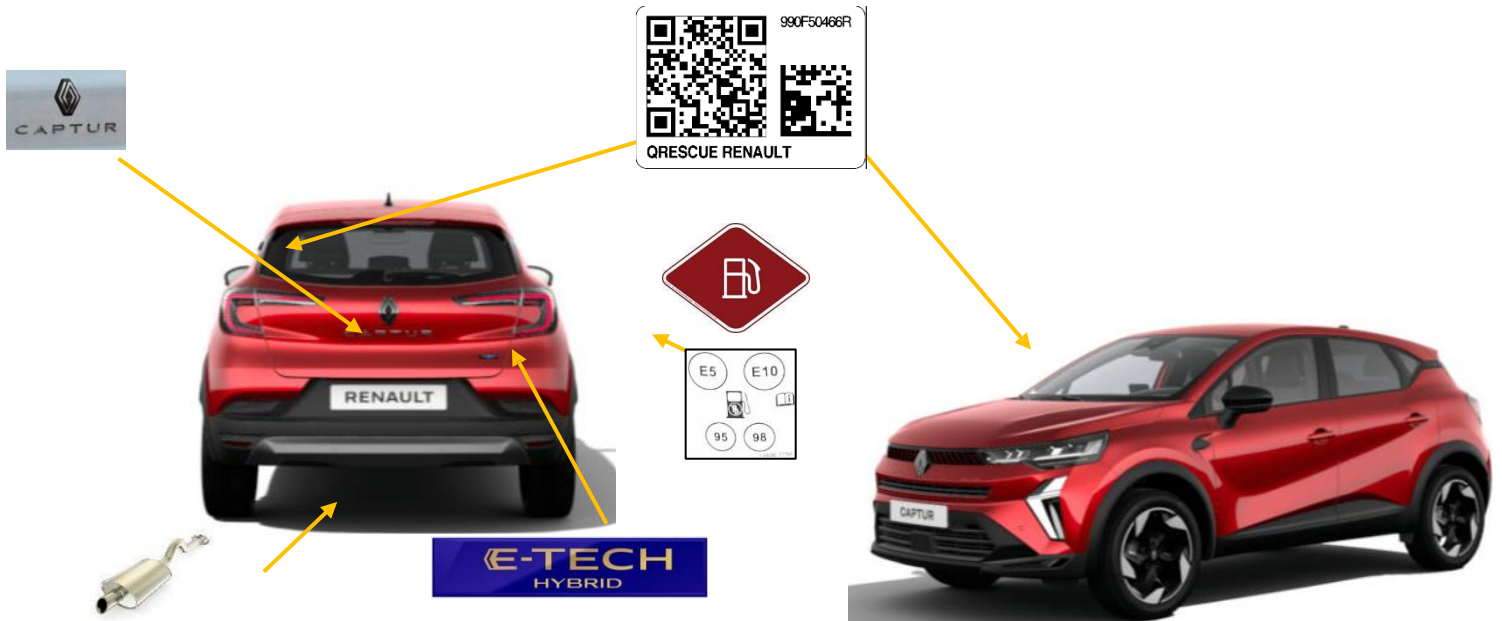

2. Immobilisation / stabilisation / lifting

Engine shutdown

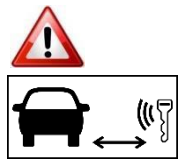

Forbidden wedge area

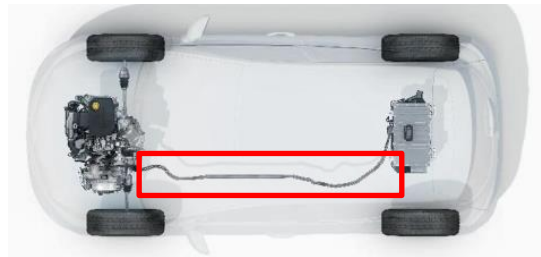

Orange cables area

3. Disable direct hazards / safety regulations

12 Volts Battery

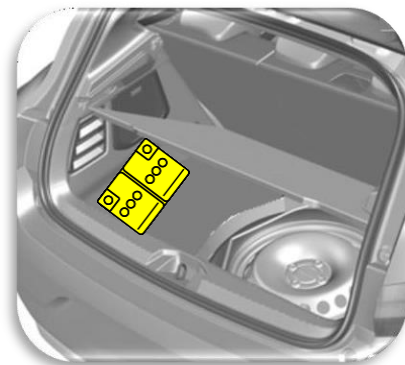
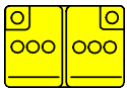

In case of airbag release, the 12V battery automatically turns off

200 Volts battery

Only if cutting operation is necessary :

Disconnection of the 200 Volts battery by removing the service plug.

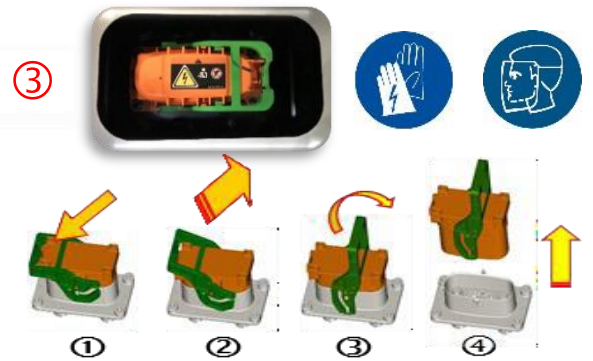
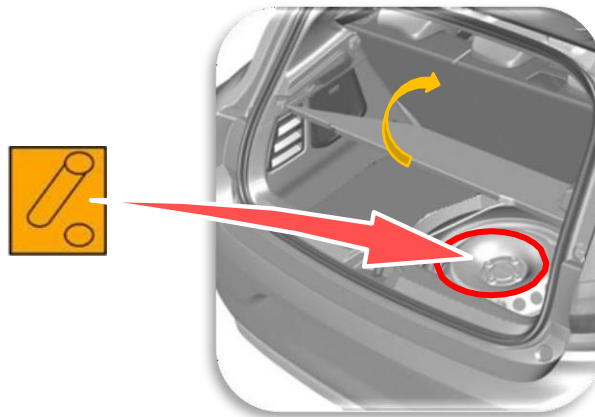

4. Access to the occupants

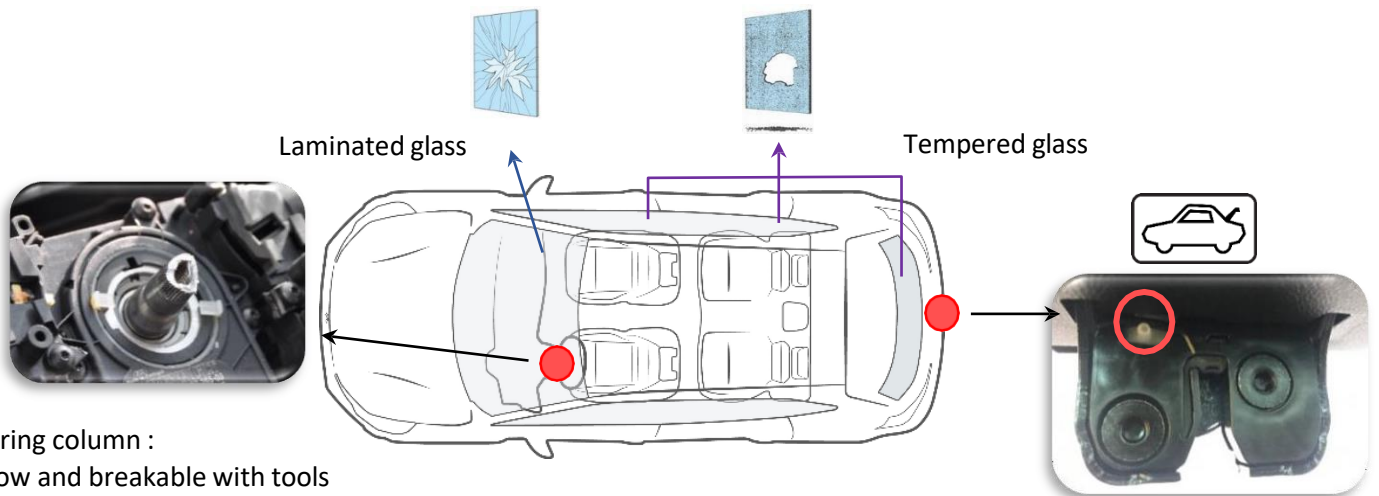

Steering column :
Hollow and breakable with tools

Possible internal manual opening

POSSIBLE MOVEMENT OF SEATS

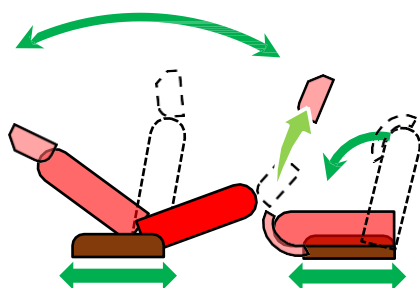

HARDENED STEEL

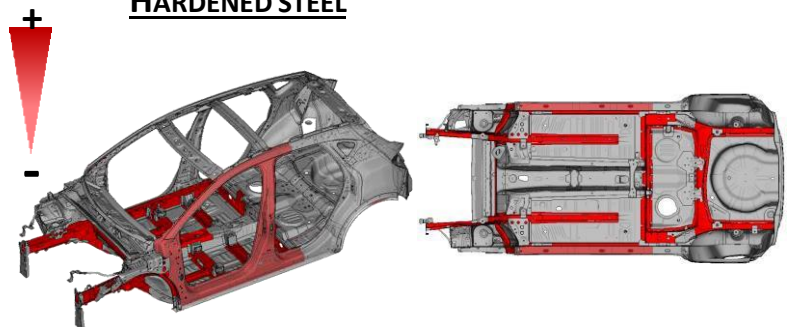

In consultation with





MINISTÈRE DE L'INTÉRIEUR

Internal reference	Date	Version	Page
RS-HJB HEV_ph1&2_2024	01/08/2024	1	3 / 4

5. Stored energy / liquids / gases / solids

	Lithium-Ion	1,2 kW.h	200 V	Casing Aluminium
---	-------------	----------	-------	------------------

			48 L
---	---	---	------

6. In case of fire

Extinguishing a traction battery fire propagation



GAS STRUTS



Risk of missile effect of gas struts

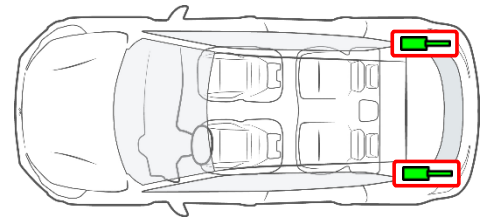











7. In case of submersion



No electrical hazard

After taking the vehicle out of the water :
Disconnection of the 200 Volts battery by removing the service plug.

10. Explanation of pictograms used

	Hybrid Electric Vehicle on fuel of liquid group 2				
	Remove smart key		Boot		Use thermal infrared camera
	Flammable		Hazardous to the human health		Environmental hazard
Electrical protection gloves 	Face shield 	Breathing apparatus (BA) 	Use water to extinguish the fire 	Don't break, nor open 