







	Airbag		Stored gas inflator		Seat belt pretensioner		SRS control unit		
	Battery low voltage		Gas strut / Preloaded spring		High strength zone		Zone requiring special attention		Fuel tank content gasoline/ethanol

	ID No.	Version No.	Version Date.	Page
	VBXG-ENRS-EN01	01	10/2024	1/4

1. Identification / recognition



2. Immobilisation / stabilisation / lifting

Immobilisation

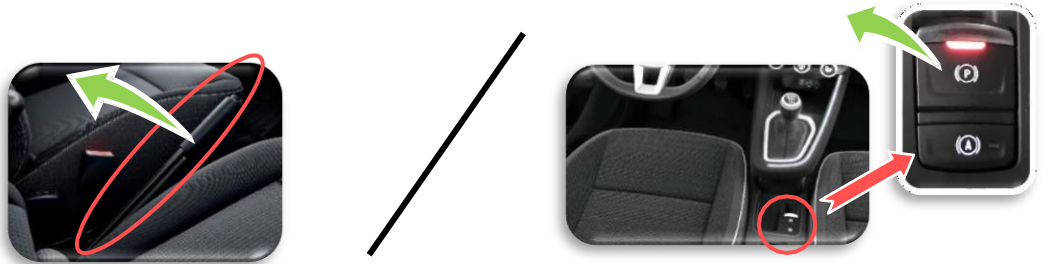

Engine shutdown



3. Disable direct hazards / safety regulations

12 Volts Battery

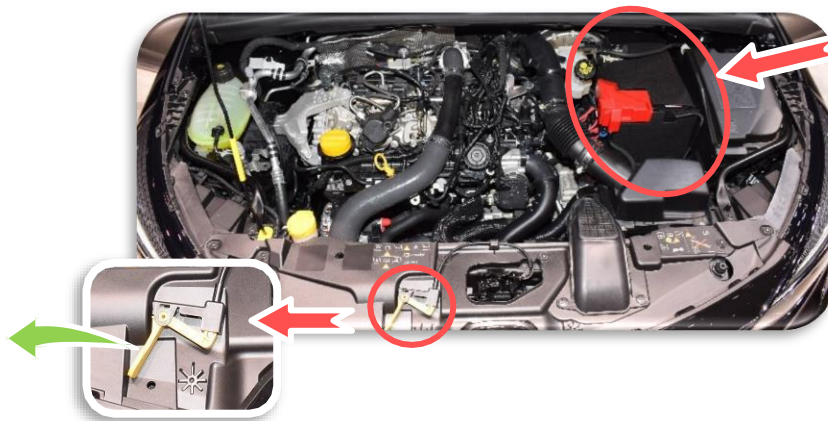
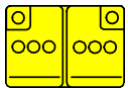

	ID No.	Version No.	Version Date.	Page
	VBXG-ENRS-EN01	01	10/2024	2/4

4. Access to the occupants

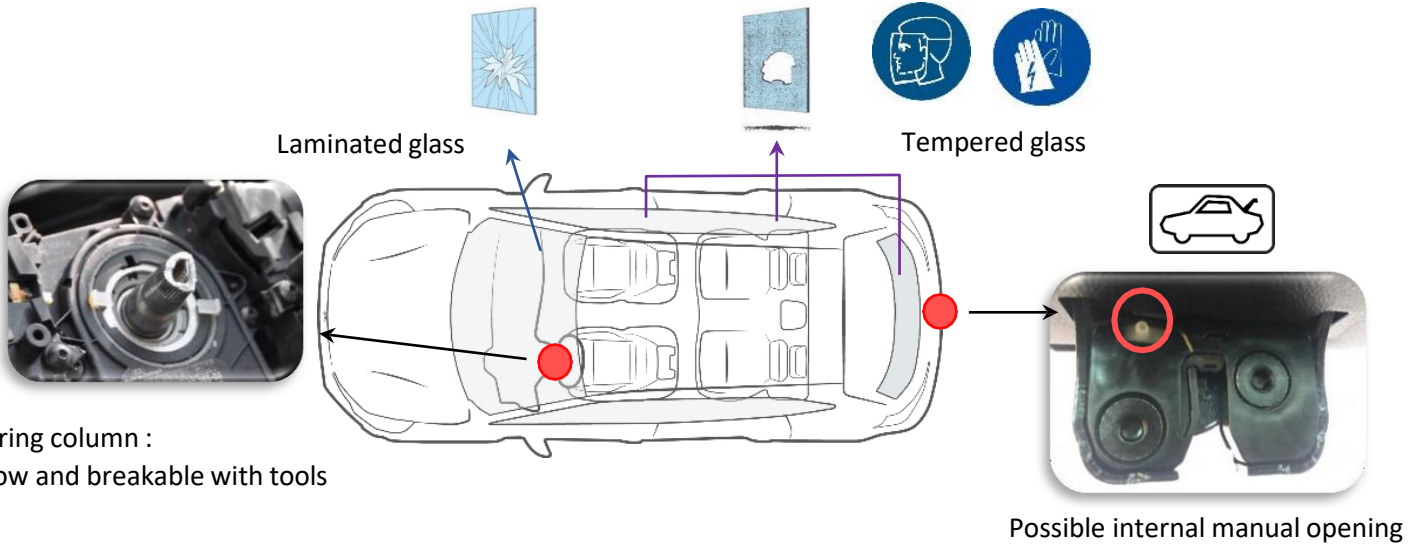



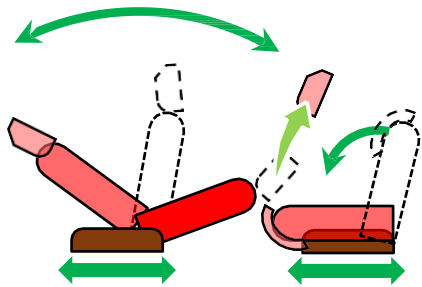

POSSIBLE MOVEMENT OF SEATS

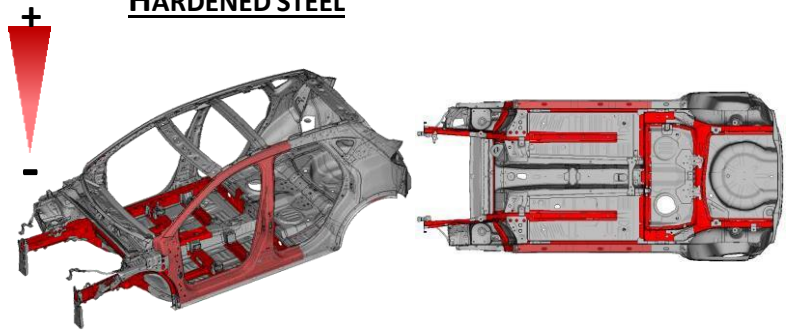

HARDENED STEEL



5. Stored energy / liquids / gases / solids

	48 L	  
---	------	---

	ID No.	Version No.	Version Date.	Page
	VBXG-ENRS-EN01	01	10/2024	3/4

6. In case of fire







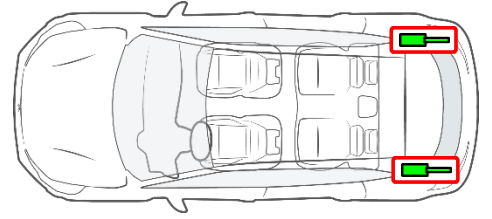



GAS STRUTS



Risk of missile effect of gas struts



10. Explanation of pictograms used

		Vehicle running on group 2 liquid fuel	
	Remove smart key		engine hood
	boot		Flammable
	Hazardous to the human health		Environmental hazard
Face shield 	Breathing apparatus (BA) 	Use water to extinguish the fire 	

	ID No.	Version No.	Version Date.	Page
	VBXG-ENRS-EN01	01	10/2024	4/4