

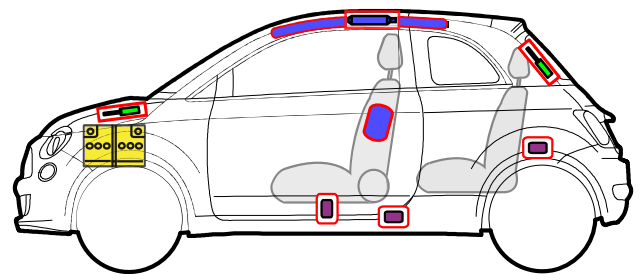

# Nuova 500

Hatchback - Cabrio - 3+1  
2020-08

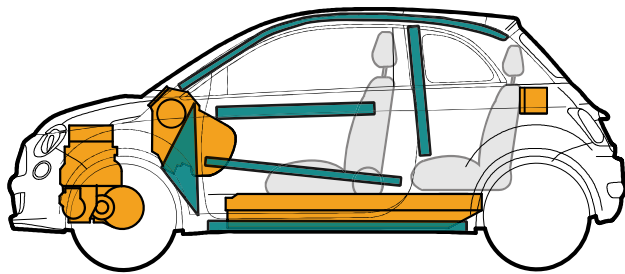
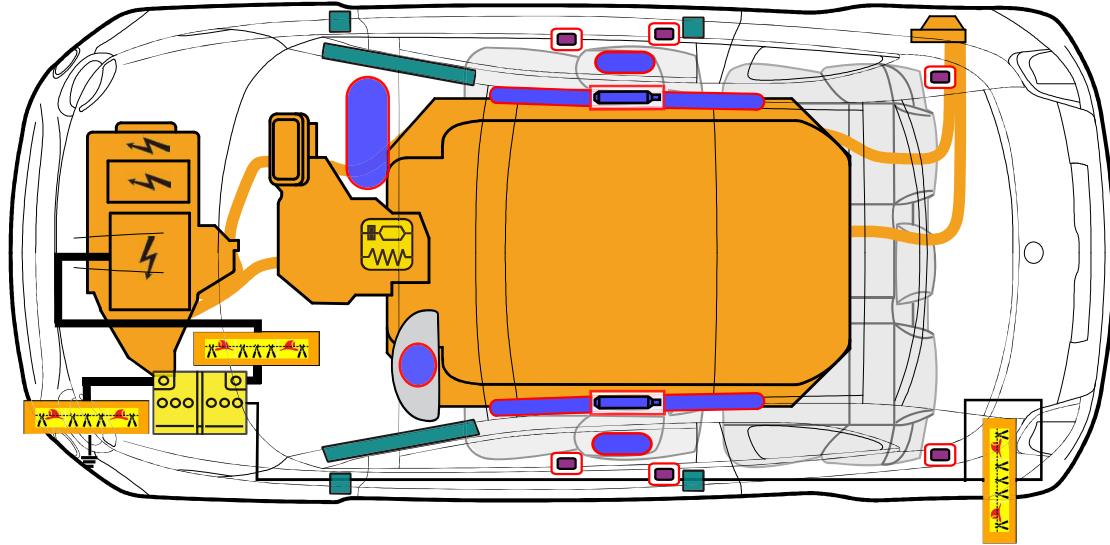

	Airbag		Stored gas inflator		Seat belt pretensioner		SRS control unit		Pedestrian protection active system
	Automatic rollover protection system		Gas strut/Preloaded spring		High strength zone		Zone requiring special attention		
	Low voltage battery		Ultracapacitor, low voltage		Fuel tank		Gas tank		Safety valve
	High voltage battery pack		High voltage power cable/component		High voltage disconnection		Fuse box disabling high voltage system		Ultra capacitor, high voltage
	Cable cut		High voltage component						

## 1. Identification / recognition

### ■ Location of the model name



### ■ Power source: Lithium-ion batteries



THERE IS THE POSSIBILITY OF SILENT MOVEMENT OR INSTANTANEOUS RESTART UNTIL THE VEHICLE IS COMPLETELY DISABLED. WEAR APPROPRIATE PERSONAL PROTECTIVE EQUIPMENT (PPE).

## 2. Immobilization/ stabilization/ lifting

### ■ Immobilize the vehicle

1. Press the brake pedal and set the selection control (A) in "P" position.

2. Activate the electric parking brake (B).



### ■ To stabilize the car, support it at all four points under the front and central pillars, using wooden blocks or equivalent objects.

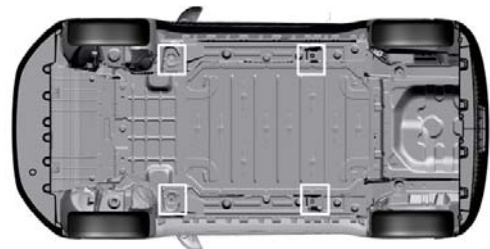

## 3. Disable direct hazards / safety regulations



1. Execute the key OFF

- Press the START-ELECTRIC-STOP pushbutton (A)



Press the START-ELECTRIC-STOP button with brake pedal NOT PRESSED

Remove the Smart Key or the "Weareable Key".

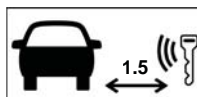



1. Open the engine hood (A,B)
2. Disconnect (or cut) the 12V battery ground cable (C)
3. Cut the low voltage cable (D) to deactivate the High Voltage, indicated by the label

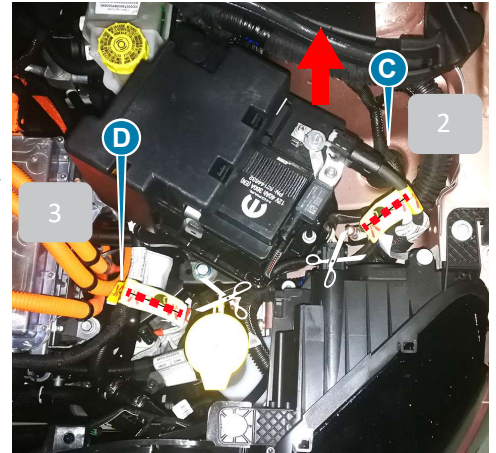
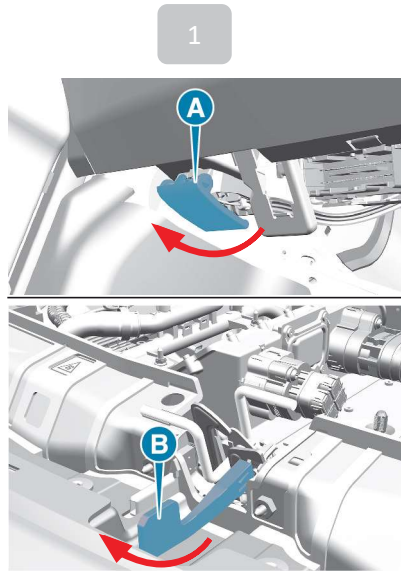
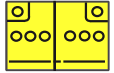

### ALTERNATIVE DISABLE METHOD



1. Open the tailgate (A)
2. Remove the cover (B)
3. Cut the low voltage cable (C) to deactivate the High Voltage, indicated by the label

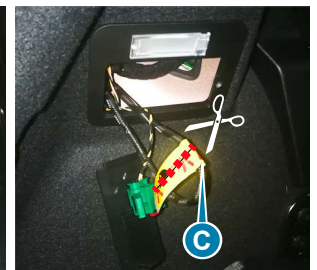
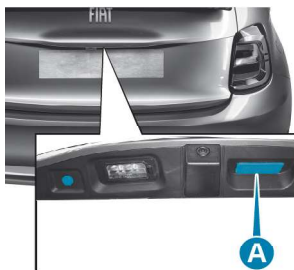

**IMPORTANT INFORMATION FOR DEACTIVATING THE HIGH VOLTAGE SYSTEM**  
**- DO NOT CUT OR DAMAGE THE ORANGE CABLES AND CONNECTORS UNDER ANY CIRCUMSTANCES**

- After an accident with Airbags deployed, the High Voltage system is automatically deactivated.
- Energy is still present in the High Voltage battery.



The orange cables and components connected to these cables are part of the High Voltage system and could be energized.



**WARNING!** If the airbags are not deployed, with key-on and with the positive and negative poles of the 12V service battery disconnected, the high voltage may remain active



**WARNING!** In case of airbags not deployed, even with key-off and with 12V service battery connected, the high voltage could be reactivated

### 4. Access to occupants

#### ■ Windows / Sunroof

- 1: Laminated glass
- 2: Tempered glass
- 3: Soft roof (rotate cw the screw A to open it)

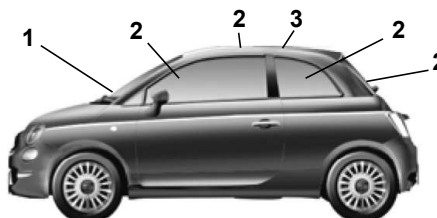

#### ■ Adjustable steering wheel



For "3+1" version:

- open the front side door (4) on right side
- open the rear side door (5)





## 5. Liquid / Solid / Gaseous energy storage devices



High Voltage  
lithium-ion battery

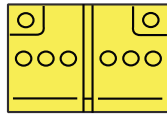

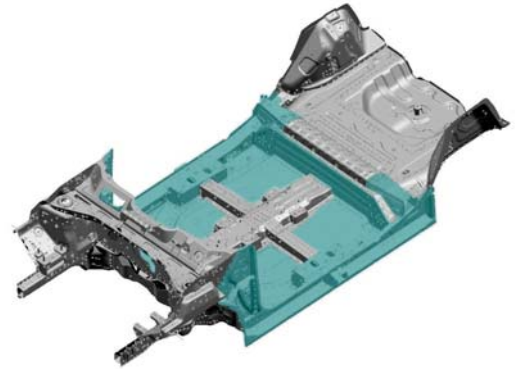

12 V battery



 High strength zone



 Avoid cutting, touching or working on High Voltage components.  
If NOT there is a real risk of injury and death. 



## 6. In case of fire

 Use large amounts of water

If it is not possible to apply large amounts of water to the high-voltage battery, it is advisable to allow the batteries to burn by themselves

**HIGH VOLTAGE BATTERY: RE-IGNITION IS POSSIBLE!**        

## 7. In case of immersion

 Do not touch high-voltage cables and components, including the charging socket, as this presents a danger of electric shock. Work on the vehicle only after pulling it out of the water. 

See Heading 3.

## 8. Towing / Transport / Storage



**HIGH VOLTAGE BATTERY: RE-IGNITION IS POSSIBLE!** 

**PARK THE VEHICLE AT A SAFE DISTANCE (15 METERS) FROM THE OTHER VEHICLES**

## 9. Important additional information

—